

AWA RT85 (Original)

2716 version

Programming Notes

These are notes collected from various sources such as VK3TAE and VK4TCS,

Includes HEX printouts of various eeprom configurations both 2716 eeprom and also the modified 2732 eeprom version using the A11 line via a switch to provide two banks of 80 channels.

By VK2KFJ.

RT85 PROGRAMMING DATA . VK3TAE 30/MAY/1997

This data will not work on the RT85A, RT85B or RT85C Models

LOCATION 3F0

The HIGHEST Channel must be placed in location 03F0

For a radio with 63 Channels fitted

EG: 0003F0 63 00 00 42 FF FF FF FF FF FF FF FF FF FF FF

LOCATION 3F1 First Bit Nibble

EG: 0003F0 63 00 00 00 FF FF FF FF FF FF FF FF FF FF FF

The first digit is filled from the following table

| | | | | | | | | |
|----------------------|---|---|---|---|---|---|---|---|
| CTCSS Decoder fitted | Y | Y | Y | Y | | | | |
| Busy Lamp Delay | Y | Y | | | Y | Y | | |
| Selcall Fitted | Y | | Y | | Y | | Y | |
| Programming Code | 7 | 6 | 5 | 4 | 3 | 2 | 1 | 0 |

LOCATION 3F1 Second Bit Nibble

EG: 0003F0 63 00 00 00 FF FF FF FF FF FF FF FF FF FF FF

| | | | | | | | | |
|------------------------------------|---|---|---|---|---|---|---|---|
| Status No. Required | Y | Y | Y | Y | | | | |
| Inhibit TX when BUSY LED ON | Y | Y | | | Y | Y | | |
| Inhibit TX when OPEN LED OFF | Y | Y | Y | Y | | | | |
| <u>CODE</u> Silent switch Active. | E | C | A | 8 | 6 | 4 | 2 | 0 |
| <u>No.</u> Silent switch Inhibited | F | D | B | 9 | 7 | 5 | 3 | 1 |

3F0 3F1 3F2 3F3
 60 00 06 72
 channels Jammer Scandeler

165 MHz — 20 01 02 52 = 20ch, Silent Inh, 60s Tx Timeout, 2.5s delay 0.2s/ch scan

LOCATION 3F2 First Digit

EG: 0003F0 63 00 00 00 FF FF FF FF FF FF FF FF FF FF FF

PTT release (ms)
hold on delay

| | | | | | | | |
|---|----|-----|-----|-----|-----|-----|-----|
| 0 | 50 | 100 | 150 | 200 | 250 | 300 | 350 |
| 0 | 1 | 2 | 3 | 4 | 5 | 6 | 7 |

CODE No.

LOCATION 3F2 Second Digit

EG: 0003F0 63 00 00 00 FF FF FF FF FF FF FF FF FF FF FF

TX Time out
timer seconds

| | | | | | | | |
|----|----|----|-----|-----|-----|-----|------|
| 30 | 60 | 90 | 120 | 150 | 180 | 210 | NONE |
| 1 | 2 | 3 | 4 | 5 | 6 | 7 | 0 |

LOCATION 3F3

EG: 0003F0 63 00 00 00 FF FF FF FF FF FF FF FF FF FF FF

Scan Stop With

Scan Hold on
Delay

Scan 0.2 sec/ch
CODE

No: Scan 0.4 sec/ch

| CTCSS TONE | | | | BUSY CHANNEL | | | |
|------------|-----|----|-----|--------------|-----|----|-----|
| 1.3 | 2.5 | 5 | 7.5 | 1.3 | 2.5 | 5 | 7.5 |
| 41 | 51 | 61 | 71 | 42 | 52 | 62 | 72 |
| 01 | 11 | 21 | 31 | 02 | 12 | 22 | 32 |

0

6

72

BANDS

| | HEX | LOCATION | 410 | 404 | AND | 40C |
|-----|-----|----------|-----|-----|-----|-----|
| 80 | 1 | | 41 | | 72 | 56 |
| 86 | 0 | | 51 | | 72 | 56 |
| 15F | D | | 32 | | 72 | 56 |
| 150 | 2 | | 02 | | 72 | 56 |
| 400 | 3 | | 03 | | 72 | 56 |

The starting ADDRESS is 00000 Scan, CTCSS/CS, RX DATA First

The finishing ADDRESS is 05FF TX data

This radio can have upto 63 channels in plus channel 0.

0-63
(64) to total.

The RX Data starts 00000 To 00018F this includes scan and ctcss.

The option data is located in locations 3F0, 3F1, 3F2, 3F3.

The TX Data starts 400 To 00058F

Each line contains 4 Channels.

EG: LINE 1 RX

00000 01 FF FF FF FF ^{146.625} 00 C3 95FF 00 ^{146.650} C3 9A FF 00 ^{146.675} C3 9F

00010 FF ^{146.700} 40 C3 A4 FF 00 ^{146.725} C3 A9FF 00 ^{146.750} C3 AE FF 00 ^{146.775} C3 B3

EG: LINE 1 TX

00400 00 FF FF FF ^{146.025} 72 00 C4 15FF 00 C4 1A 56 00 C4 1F

00410 02 40 C4 24 FF 00 C4 29FF 00 C4 2E FF 40 C4 33

SCAN

There can only be 31 scanning channels. This data is in RX data section.

00000 01 FF FF FF 02 00 C3 95 03 00 C3 9A 04 00 C3 9F

00010 05 40 C3 A4 06 00 C3 A9 07 40 C3 AE 08 40 C3 B3

00020 09 41 C3 A4 10 41 C3 A9 FF 01 C3 AE FF 01 C3 B3

SCAN in the above is programed between 1 to 10

Enter the channels you want to scan starting at the first location

and then every fifth location up to location 00078 which is the

31'st scan location. Numbers can be in any order.

EG: 01.10. 02. 08. 09. 32. 20. 40. 41. 42. 63.

D:\WORD6\RADIO\RT85.DOC

00 C3 95 c 3 9 5
 |100 0011 1001 0101 Even's , but ~~odd~~

RT85 EPROM PROGRAMMING CTCSS CODEING.

CTCSS IS LOCATED BEFORE THE CHANNEL DATA. Depending upon the Check sum the data may be 40hex higher.

(5kHz) On 25Khz Spacing 00 and 40 are used for no CTCSS VHF ~~EVEN~~
 On 12.5 KHz Spacing 01 and 41 are used for no CTCSS VHF ~~ODD~~

| ODD | EVEN | FREQ IN Hz |
|-----|------|-----------------------|
| 01 | 41 | NO CTCSS or 00 and 40 |
| 3F | 7F | 71.9 |
| 3D | 7D | 77.0 |
| 3B | 7B | 82.5 |
| 39 | 79 | 88.5 |
| 37 | 77 | 94.8 |
| 35 | 75 | 100.0 |
| 33 | 73 | 103.5 |
| 31 | 71 | 107.2 |
| 2F | 6F | 110.9 |
| 2D | 6D | 114.8 |
| 2B | 6B | 118.8 |
| 29 | 69 | 123.0 |
| 27 | 67 | 127.3 |
| 25 | 65 | 131.8 |
| 23 | 63 | 136.5 |
| 21 | 61 | 141.3 |
| 1F | 5F | 146.2 |
| 1D | 5D | 151.4 |
| 1B | 5B | 156.7 |
| 19 | 59 | 162.2 |
| 17 | 57 | 167.9 |
| 15 | 55 | 173.8 |
| 13 | 53 | 179.9 |
| 11 | 51 | 186.2 |
| 0F | 4F | 192.8 |
| 0D | 4D | 203.5 |
| 0B | 4B | 210.7 |
| 09 | 49 | 218.1 |
| 07 | 47 | 225.7 |
| 05 | 45 | 233.6 |
| 03 | 43 | 241.8 |

Data info on HEX 00, 40, 01, 41 that is placed before the frequency bits.

5 4 3 2 1 3 4 2 1

| | | | | | | | |
|------|-----------------|---|---|---|---|---|-------|
| 0 | 1 | 0 | 0 | 0 | 0 | 0 | 0 |
| ---- | EVEN | 8 | 4 | 2 | 1 | X | 5 KHz |

CTCSS CODE SPACING

| | | | | | | | |
|------|----------------|---|---|---|---|---|----------|
| 0 | 0 | 0 | 0 | 0 | 0 | 0 | 1 |
| ---- | ODD | 8 | 4 | 2 | 1 | X | 12.5 KHz |

In the freq dat, count the number of bits set to 1
 If even number c/s is set to 1. i.e 40 or 41
 If odd number c/s is set to 0. i.e 00 or 01

VHF
f_{ref} Hi & Lo

VHF
f_{ref} Hi & Lo

5kHz ch. 12.5kHz ch.

EPROM PROGRAMMING SCHEDULE
AKA CARPHONE RT-85

CUSTOMER: DATE:
TYPE NO: REF NO:

FREQ. BAND VHF (LW) 1 VHF (HB) 2 VHF 3 (Tick box required)

| CHANNEL | 1 RX FREQUENCY (MHz) | 2 RX CTCSS/AUX CODES | 3 TX FREQUENCY (MHz) | 4 TX CTCSS/AUX CODES | SCAN ORDER | |
|---------|----------------------------|-------------------------------|----------------------------|-------------------------------|------------|----|
| | | | | | CH | CH |
| | | | | | 0 | 11 |
| 1 | | | | | 1 | 12 |
| 2 | | | | | 2 | 13 |
| 3 | | | | | 3 | 14 |
| 4 | | | | | 4 | 15 |
| 5 | | | | | 5 | 16 |
| 6 | | | | | 6 | 17 |
| 7 | | | | | 7 | 18 |
| 8 | | | | | 8 | 19 |
| 9 | | | | | 9 | 20 |
| 10 | | | | | 10 | 21 |
| 11 | | | | | | |
| 12 | | | | | | |
| 13 | | | | | | |
| 14 | | | | | | |
| 15 | | | | | | |
| 16 | | | | | | |
| 17 | | | | | | |
| 18 | | | | | | |
| 19 | | | | | | |
| 20 | | | | | | |

Use 15th sheet if more than 20 channels required

Note: See other side for information on personality codes and Rx & Tx CTCSS/
Auxiliary Codes.

Other Comments:

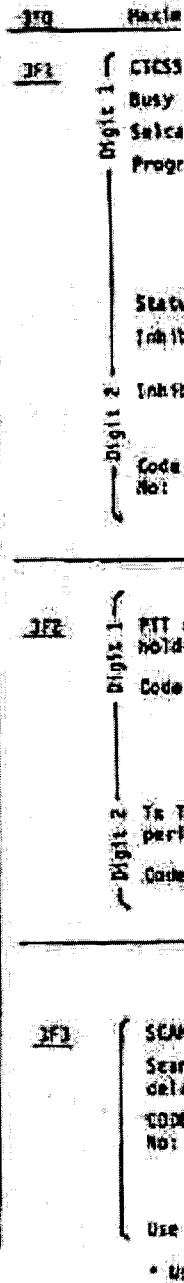

Fig. P-1 Blank EPROM Programming Schedule

EPROM PROGRAMMING SCHEDULE
W/A. SANYO SE-95

CUSTOMER: DATE:
 TYPE NO: REF NO:

FREQ. BAND: HF (LF) VHF (HF) HF 3 (Tick box required)

| CHANNEL | RX FREQUENCY (MHz) | NR. CROSS/AUX CODES | TX FREQUENCY (MHz) | TX CROSS/AUX CODES | SCAN ORDER | |
|---------|--------------------|---------------------|--------------------|--------------------|------------|----|
| | | | | | CR | CA |
| 1 | | | | | 0 | 11 |
| 2 | | | | | 1 | 12 |
| 3 | | | | | 2 | 13 |
| 4 | | | | | 3 | 14 |
| 5 | | | | | 4 | 15 |
| 6 | | | | | 5 | 16 |
| 7 | | | | | 6 | 17 |
| 8 | | | | | 7 | 18 |
| 9 | | | | | 8 | 19 |
| 10 | | | | | 9 | 20 |
| 11 | | | | | 10 | 21 |
| 12 | | | | | | |
| 13 | | | | | | |
| 14 | | | | | | |
| 15 | | | | | | |
| 16 | | | | | | |
| 17 | | | | | | |
| 18 | | | | | | |
| 19 | | | | | | |
| 20 | | | | | | |

PERSONALITY CODES

3FD
 3F1
 3F2
 3F3

PERSONALITY PROGRAMMING CODES

3F0 Hexagram Channel No.

| | | | | | | | | | |
|---|---|---|---|---|---|---|---|---|---|
| 1 | 2 | 3 | 4 | 5 | 6 | 7 | 8 | 9 | 0 |
| 1 | 2 | 3 | 4 | 5 | 6 | 7 | 8 | 9 | 0 |

3F1 Status No. requirement

| | | | | | | | | | |
|---|---|---|---|---|---|---|---|---|---|
| 1 | 2 | 3 | 4 | 5 | 6 | 7 | 8 | 9 | 0 |
| 1 | 2 | 3 | 4 | 5 | 6 | 7 | 8 | 9 | 0 |

3F2 RTI release (ms)

| | | | | | | | |
|---|----|-----|-----|-----|-----|-----|-----|
| 0 | 50 | 100 | 150 | 200 | 250 | 300 | 350 |
| 0 | 1 | 2 | 3 | 4 | 5 | 6 | 7 |

3F3 Tx Time out Sec

| | | | | | | | |
|----|----|----|-----|-----|-----|-----|-----|
| 30 | 60 | 90 | 120 | 150 | 180 | 210 | 240 |
| 1 | 2 | 3 | 4 | 5 | 6 | 7 | 8 |

| NO | CODE | CT |
|----|------|----|
| 0 | 1 | 2 |
| 1 | 3 | 4 |
| 2 | 5 | 6 |
| 3 | 7 | 8 |
| 4 | 9 | 10 |
| 5 | 11 | 12 |
| 6 | 13 | 14 |
| 7 | 15 | 16 |
| 8 | 17 | 18 |
| 9 | 19 | 20 |
| 10 | 21 | 22 |
| 11 | 23 | 24 |
| 12 | 25 | 26 |
| 13 | 27 | 28 |
| 14 | 29 | 30 |
| 15 | 31 | 32 |

Use 1200 Hz pulse if same than 3000 Hz pulse

Fig. P-1 Blank EPROM Programming Schedule

Hex Details for File C:\MIDLAND\CBC\CHUCK.DAT
THESE ARE THE SEAM ORDER OF THE CHANNELS - MAX OF 32.

CHAN. NUMBER (LAST HIGHLIGHTED ONE)

| Address | 0 | 1 | 2 | 3 | 4 | 5 | 6 | 7 | 8 | 9 | A | B | C | D | E | F | Chan. # |
|---------|----|----|----|----|----|----|----|----|----|----|----|----|----|----|----|----|---------|
| 0000 | FF | FF | FF | FF | 41 | 1C | 32 | 41 | 1C | 34 | 01 | 1C | 38 | 2 | | | |
| 0010 | 41 | 1C | 38 | 08 | 01 | 1C | 3A | 07 | 01 | 1C | 3C | 08 | 41 | 1C | 3E | 7 | |
| 0020 | 41 | 1C | 80 | 42 | 01 | 1C | 82 | 43 | FF | FF | FF | 44 | FF | FF | FF | 9 | |
| 0030 | 45 | FF | FF | FF | 45 | FF | FF | FF | 47 | FF | FF | FF | 48 | FF | FF | FF | 13 |
| 0040 | 49 | 01 | 1C | 84 | 50 | 41 | 1C | 86 | 51 | 01 | 1C | 88 | 52 | 41 | 1C | 8A | 17 |
| 0050 | 53 | 41 | 1C | 8C | 54 | 01 | 1C | 8E | 55 | 01 | 1C | 90 | 56 | 41 | 1C | 92 | 19 |
| 0060 | 57 | 41 | 1C | 94 | 58 | 01 | 1C | 96 | 59 | FF | FF | FF | 60 | FF | FF | FF | 23 |
| 0070 | 61 | FF | FF | FF | 62 | FF | FF | FF | 63 | FF | FF | FF | 64 | FF | FF | FF | 27 |
| 0080 | FF | 41 | 1C | 98 | FF | 01 | 1C | 9A | FF | 01 | 1C | 9C | FF | 41 | 1C | 9E | 29 |
| 0090 | FF | 01 | 1C | A0 | FF | 41 | 1C | A2 | FF | 41 | 1C | A4 | FF | 01 | 1C | A6 | 33 |
| 00A0 | FF | 41 | 1C | A8 | FF | 01 | 1C | AA | FF | FF | FF | FF | FF | FF | FF | FF | 37 |
| 00B0 | FF | FF | FF | FF | FF | FF | FF | FF | FF | FF | FF | FF | FF | FF | FF | FF | 41 |
| 00C0 | FF | 01 | 1C | AC | FF | 01 | 1C | AE | FF | 41 | 1D | 00 | FF | 01 | 17 | 32 | 45 |
| 00D0 | FF | 01 | 17 | 34 | FF | 43 | 17 | 36 | FF | 01 | 17 | 10 | FF | 41 | 17 | 12 | 49 |
| 00E0 | FF | 41 | 17 | 14 | FF | 01 | 17 | 16 | FF | FF | FF | FF | FF | FF | FF | FF | 53 |
| 00F0 | FF | FF | FF | FF | FF | FF | FF | FF | FF | FF | FF | FF | FF | FF | FF | FF | 57 |
| 0100 | FF | 41 | 17 | 18 | FF | 01 | 17 | 1A | FF | 01 | 17 | 1C | FF | 41 | 17 | 1E | 61 |
| 0110 | FF | 01 | 17 | 20 | FF | 41 | 17 | 22 | FF | 41 | 17 | 24 | FF | 01 | 17 | 26 | 65 |
| 0120 | FF | 41 | 17 | 28 | FF | 01 | 17 | 2A | FF | FF | FF | FF | FF | FF | FF | FF | 69 |
| 0130 | FF | FF | FF | FF | FF | FF | FF | FF | FF | FF | FF | FF | FF | FF | FF | FF | 73 |
| 0140 | FF | 01 | 17 | 2C | FF | 41 | 17 | 2E | FF | 41 | 17 | 30 | FF | 01 | 17 | 32 | 77 |
| 0150 | FF | 01 | 17 | 34 | FF | 41 | 17 | 36 | FF | 01 | 17 | 38 | FF | 41 | 17 | 3A | 81 |
| 0160 | FF | 01 | 17 | A2 | FF | 01 | 18 | 08 | FF | FF | FF | FF | FF | FF | FF | FF | 85 |
| 0170 | FF | FF | FF | FF | FF | FF | FF | FF | FF | FF | FF | FF | FF | FF | FF | FF | 89 |
| 0180 | FF | 01 | 17 | 80 | FF | 41 | 17 | 8E | FF | 41 | 18 | 00 | FF | 01 | 18 | 02 | 93 |
| 0190 | FF | 01 | 18 | 04 | FF | FF | FF | FF | FF | FF | FF | FF | FF | FF | FF | FF | 97 |
| 01A0 | FF | FF | FF | FF | FF | FF | FF | FF | FF | FF | FF | FF | FF | FF | FF | FF | 101 |
| 01B0 | FF | FF | FF | FF | FF | FF | FF | FF | FF | FF | FF | FF | FF | FF | FF | FF | 105 |
| 01C0 | FF | FF | FF | FF | FF | FF | FF | FF | FF | FF | FF | FF | FF | FF | FF | FF | 109 |
| 01D0 | FF | FF | FF | FF | FF | FF | FF | FF | FF | FF | FF | FF | FF | FF | FF | FF | 113 |
| 01E0 | FF | FF | FF | FF | FF | FF | FF | FF | FF | FF | FF | FF | FF | FF | FF | FF | 117 |
| 01F0 | FF | FF | FF | FF | FF | FF | FF | FF | FF | FF | FF | FF | FF | FF | FF | FF | 121 |
| 0200 | FF | FF | FF | FF | 00 | 41 | 1C | 32 | 00 | 41 | 1C | 34 | 00 | 01 | 1C | 38 | 125 |
| 0210 | 00 | 41 | 1C | 38 | 00 | 01 | 1C | 3A | 00 | 01 | 1C | 3C | 00 | 41 | 1C | 3E | 129 |
| 0220 | 00 | 41 | 1C | 80 | 00 | 01 | 1C | 82 | FF | FF | FF | FF | FF | FF | FF | FF | 133 |
| 0230 | FF | FF | FF | FF | FF | FF | FF | FF | FF | FF | FF | FF | FF | FF | FF | FF | 137 |
| 0240 | 00 | 01 | 1C | 84 | 00 | 41 | 1C | 86 | 00 | 01 | 1C | 88 | 00 | 41 | 1C | 8A | 141 |
| 0250 | FF | FF | FF | FF | FF | FF | FF | FF | FF | FF | FF | FF | FF | FF | FF | FF | 145 |
| 0260 | FF | FF | FF | FF | FF | FF | FF | FF | FF | FF | FF | FF | FF | FF | FF | FF | 149 |
| 0270 | 00 | FF | FF | FF | 12 | 41 | 1E | 18 | 04 | 01 | 1E | 20 | 08 | 41 | 1E | 22 | 153 |
| 0280 | 00 | FF | FF | FF | FF | 01 | 1E | 24 | FF | 41 | 1E | 28 | FF | 01 | 1E | 2A | 157 |
| 0290 | FF | 01 | 1E | 2C | FF | 01 | 1D | 08 | FF | FF | FF | FF | FF | FF | FF | FF | 161 |
| 0300 | FF | FF | FF | FF | FF | FF | FF | FF | FF | FF | FF | FF | FF | FF | FF | FF | 165 |
| 0310 | FF | 41 | 1D | 04 | FF | 01 | 1D | 08 | FF | 41 | 1D | 08 | FF | 01 | 1D | 0A | 169 |
| 0320 | FF | 01 | 1D | 0C | FF | 41 | 1D | 0E | FF | 41 | 1E | 00 | FF | 01 | 1E | 02 | 173 |
| 0330 | FF | 01 | 1E | 04 | FF | 41 | 1E | 08 | FF | FF | FF | FF | FF | FF | FF | FF | 177 |
| 0340 | FF | FF | FF | FF | FF | FF | FF | FF | FF | FF | FF | FF | FF | FF | FF | FF | 181 |
| 0350 | FF | 01 | 1E | 08 | FF | 41 | 1E | 0A | FF | 41 | 1E | 0C | FF | 01 | 1E | 0E | 185 |
| 0360 | FF | 01 | 1E | 10 | FF | 41 | 1E | 12 | FF | 41 | 1E | 14 | FF | 01 | 1E | 16 | 189 |
| 0370 | FF | 41 | 1E | 18 | FF | 01 | 1E | 1A | FF | FF | FF | FF | FF | FF | FF | FF | 193 |
| 0380 | FF | FF | FF | FF | FF | FF | FF | FF | FF | FF | FF | FF | FF | FF | FF | FF | 197 |
| 0390 | FF | 01 | 1D | 10 | FF | 41 | 1D | 14 | FF | 41 | 1D | 18 | FF | 01 | 1D | 1C | 201 |
| 0400 | FF | 01 | 1D | 18 | FF | 41 | 1D | 1C | FF | 41 | 1D | 20 | FF | 01 | 1D | 24 | 205 |

CHANNEL DATA SUPPRESSED BY SOME PROGRAMMES (FOR NOT NECESSARY)

POSSIBLE EXTRA CHANNELS (TOTAL = 80)

CHANNELS FOR CLARITY

PERSONALITY CODE

24 Chan.

CODES

XTRC
FILTER

MP PROGRAMS SYNTHESIZER
EXCITER D10 ± SYNT. = TX I/F
70-1000C User Manual Version 1.0
MP PROG SYNT. DIVIDER

| Band Code | Modifier Code | Bandwidth MHz | DCIF MHz | TXIF MHz | REF kHz | Local Injection |
|-----------|---------------|---------------|----------|----------|---------|-----------------|
| 0 | - | 25-55 | 10.7 | 10.24 | 5.0 | High |
| 0 | A | 25-55 | 10.7 | 10.24 | 5.0 | Low |
| 0 | B | 25-55 | 10.7 | 9.6 | 12.5 | High |
| 0 | C | 25-55 | 10.7 | 9.6 | 12.5 | Low |
| 0 | D | 25-55 | 10.7 | 10.24 | 2.5 | High |
| 0 | E | 25-55 | 10.7 | 10.24 | 2.5 | Low |
| 1 | - | 60-90 | 21.4 | 20.48 | 5.0 | High |
| 1 | A | 60-90 | 21.4 | 20.48 | 5.0 | Low |
| 1 | B | 60-90 | 21.4 | 19.2 | 12.5 | High |
| 1 | C | 60-90 | 21.4 | 19.2 | 12.5 | Low |
| 1 | D | 60-90 | 21.4 | 20.48 | 2.5 | High |
| 1 | E | 60-90 | 21.4 | 20.48 | 2.5 | Low |
| 2 | - | 136-174 | 21.4 | 20.48 | 5.0 | Low |
| 2 | A | 136-174 | 21.4 | 20.48 | 5.0 | High |
| 2 | B | 136-174 | 21.4 | 19.2 | 12.5 | Low |
| 2 | C | 136-174 | 21.4 | 19.2 | 12.5 | High |
| 2 | D | 136-174 | 21.4 | 20.48 | 2.5 | Low |
| 2 | E | 136-174 | 21.4 | 20.48 | 2.5 | High |
| 3 | - | 403-520 | 21.4 | 19.2 | 12.5 | Low |
| 3 | A | 403-520 | 21.4 | 19.2 | 12.5 | High |
| 3 | B | 403-520 | 21.4 | 20.48 | 10.0 | Low |
| 3 | C | 403-520 | 21.4 | 20.48 | 10.0 | High |
| 3 | D | 403-520 | 21.4 | 20.48 | 5.0 | Low |
| 3 | E | 403-520 | 21.4 | 20.48 | 5.0 | High |
| 4 | - | 808-896 | 47.0 | 19.2 | 12.5 | Low |
| 4 | A | 808-896 | 47.0 | 19.2 | 12.5 | High |

Figure 31. Band Selection Table.

The current settings for the Band is shown in the CHANNELS window of the 70-1000C software, as can be seen in Figure 29.

3.4.2 Modifier

When selecting the Modifier option, the following screen is displayed.

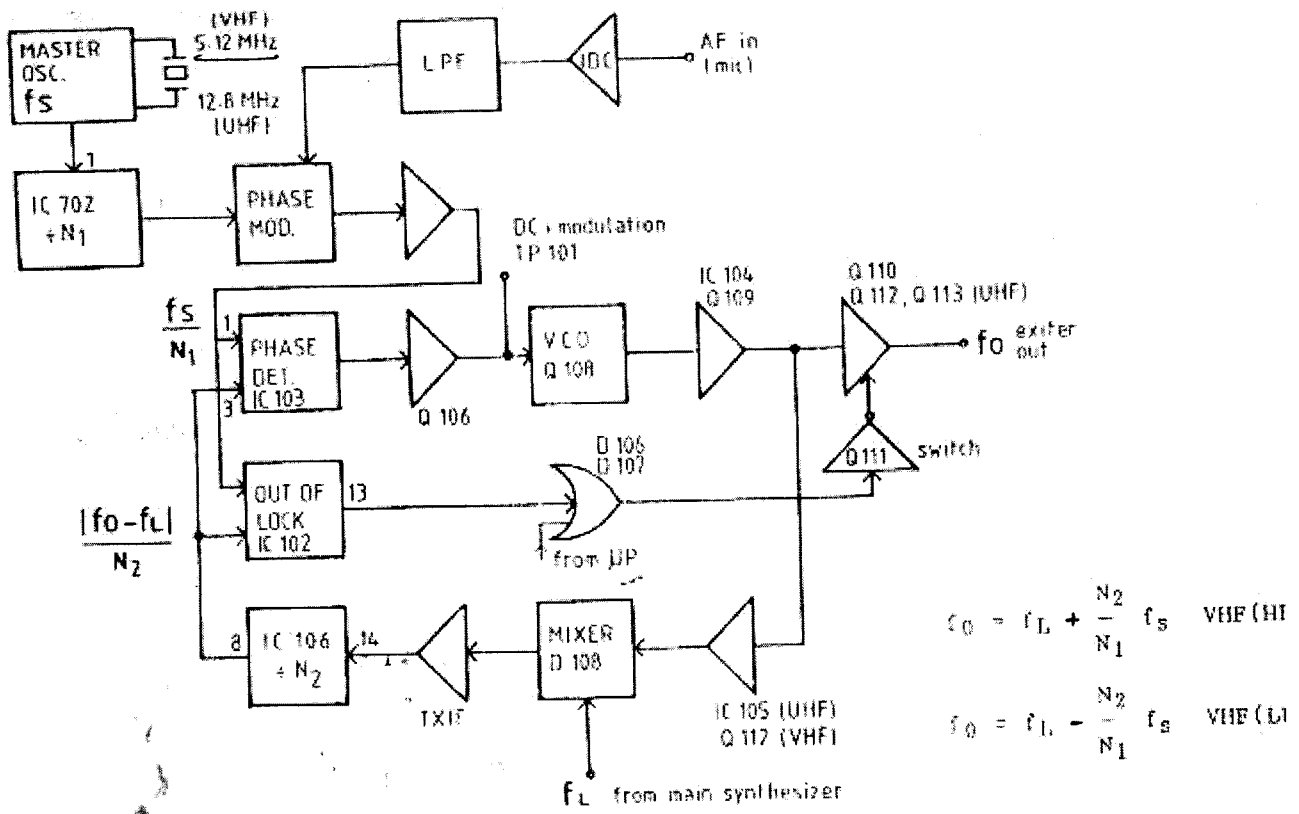

VHF H. :
 $f_s = 5.21 \text{ MHz}$
 $N_2 = 10$
 $N_1 = 1024$
 f_L

